

1100 Litre Bin Lifter

Model: VLR-2240.1100I

The Pakmor 1100 Litre Hydraulic Bin Lifter is a heavy duty machine specifically designed for emptying 120, 240, 660 & 1100 Litre plastic mobile garbage bins. The system utilizes an electric motor, hydraulic power unit and cylinders to operate.

The Bin Lifter is mounted inside a Safety Cage and electric interlocked access door.

Machine guarding and access interlocks are designed to comply with Australian Standards.

Front or side loading access to safety cage, tipping high, lift capacity etc. are all customised to suit site and or customer requirements.

Lifters can be supply on castor wheels or feet mounts to bolt directly to a concrete slab

Specifications:

Plastic Bin Size	: 120 - 1100 Litre
Lifter Capacity	: 350 kg
Electric Motor	: 3 kw
Power Supply	: 412V, 3 phase, 10amp, 5 Pin

Schematics Layout:

1100 Litre Bin Lifter with Side loading access
All dimensions are in mm

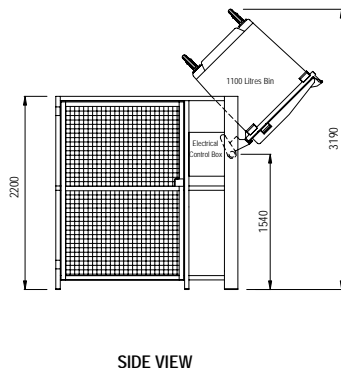
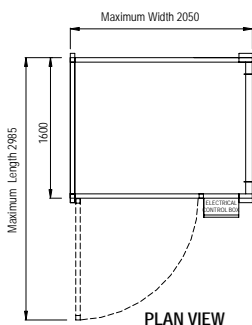

PAKMOR

PAKMOR Waste Equipment Aust. Pty. Ltd



PAKMOR Waste Equipment Aust. Pty. Ltd

P.O. Box 6044

SOUTH WINDSOR NSW 2756

email: sales@pakmor.com.au

Phone: +61 2 4577 3099

Fax: +61 2 4577 3022

website: www.pakmor.com.au