

# 240 Litre Bin Lifter

**Model: VLR-1240.240I**

The Pakmor 240 Litre Hydraulic Bin Lifter is a heavy duty machine specifically designed for emptying 120 & 240 Litre plastic mobile garbage bins. The system utilizes an electric motor, hydraulic power unit and cylinders to operate.

The Bin Lifter is mounted inside a Safety Cage and electric interlocked access door.

Machine guarding and access interlocks are designed to comply with Australian Standards.

Front or side loading access to safety cage, tipping high, lift capacity etc. are all customised to suit site and or customer requirements.

Lifters can be supply on castor wheels or feet mounts to bolt directly to a concrete slab



## Specifications:

Plastic Bin Size	: 120 - 240 Litre
Lifter Capacity	: 350 kg
Electric Motor	: 3 kw
Power Supply	: 415V, 3 phase, 10amp, 5 Pin

## Schematics Layout:

**240 Litre Bin Lifter with Side loading access**

All dimensions are in mm

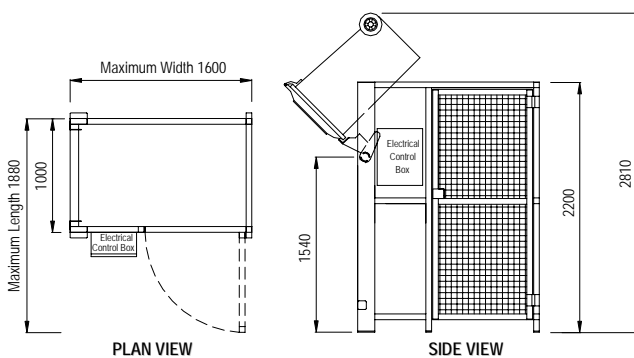

# PAKMOR

PAKMOR Waste Equipment Aust. Pty. Ltd



**PAKMOR Waste Equipment Aust. Pty. Ltd**

P.O. Box 6044

SOUTH WINDSOR NSW 2756

email: [sales@pakmor.com.au](mailto:sales@pakmor.com.au)

Phone: +61 2 4577 3099

Fax: +61 2 4577 3022

website: [www.pakmor.com.au](http://www.pakmor.com.au)